

**MOSCOW
TRAVEK
20-21 March 2012**

**XII-th International scientific and technical Conference
«Prospects of development of electric power industry and
the high-voltage electro technical equipment.
Energy efficiency and energy saving»**

**RELIABLE QUALITY AND OPTIMIZED DESIGN OF COMPONENTS
FOR POWER TRANSFORMERS AND REACTORS**

Selim Yürekten

Enpay Transformer Components

RELIABLE QUALITY AND OPTIMIZED DESIGN OF COMPONENTS FOR POWER TRANSFORMERS AND REACTORS S. Yürekten, Enpay Transformer Components

SUMMARY

The design of power transformers is today much more complicated than it was before. The necessity for engineers to overcome problems has created a demand for more basic knowledge, better materials and improved techniques. The grids need reliable equipment as transformers, reactors etc. Main parts of this equipment are magnetic circuit and insulation. In order to smoothly complete the production and tests in time, transformer and reactor producers need challenges and solutions from reliable component suppliers.

Key words: Power transformer, reactor, current transformer, core, core and tank shielding, insulation, lead exit, Transformerboard.

INTRODUCTION

Power transformers are one of the most important and expensive assets in the transmission and distribution of energy. Reliability of transformers plays a significant role in the operation of a power system. One another issue is the standardization of large power transformers with new modern technologies.

Enpay group has fully mastered the world's cutting-edge technology of UHV transformers and reactors research, made a great contribution to transformer producers. It developed new systems and components to better deal with the manufacturing difficulties. One of the most important challenges to reduce the cost of transformers without compromise the quality is the optimization of core and insulation components design.

1. MAGNETIC TECHNOLOGY

Cores for transformers (including instrument transformers) and reactors, flux collectors (for tank and core shielding) and amorphous cores [3, 4, 7]

With the state –of –the –art design and manufacturing processes can reduce the core losses and magnetostrictions. With the cost effective steel selection it is possible to reach economic target. Approximately 30-35 % of the transformer cost is constituted by core.



ENPAY Endüstriyel Pazarlama ve Yatırım A.Ş.

Karadenizliler Mahallesi Fakülte Caddesi, No: 147/A PK. 91, 41140 Başiskele - KOCAELI / TURKEY

Tel: +90 262 349 58 20 pbx Fax: +90 262 349 58 30

Most important studies and design challenges for transformers and reactors are in the following major areas:

- Electromagnetic design (for eddy and stray loss control)
- Electrostatic design (for dielectric)
- Electrodynamics design (for short circuit withstand capability)
- Thermal design (for hotspot control)
- Structural design (for transportation, vacuum, pressure withstand capability) [1]

2

General Requests on Transformer Cores:

- Low no load Losses
- Low eddy Losses and low heating in carbon steel parts.
- Optimized Flux Distribution
- Low noise
- Not hot spots

Stray Loss problem becomes increasingly important with the growing of transformer ratings.

Stray Flux is coming perpendicular in Legs and induces big eddy currents, big losses in core parts with big widths. In case of small widths also eddy currents and losses will be smaller.

Below figure red lines shows the stray flux lines.



For controlling Stray Losses in Structural Components; magnetic shunts are very effective (magnetic Shielding). The height of magnetic shunts should be higher than the height of windings (Approximately) from top yoke-center to the level of bottom Yoke-center).The optimum can be found with FEM analysis. [2] Magnetic shunts on tank wall figure show an arrangement of magnetic shunts a tank wall in a 3-phase transformer.

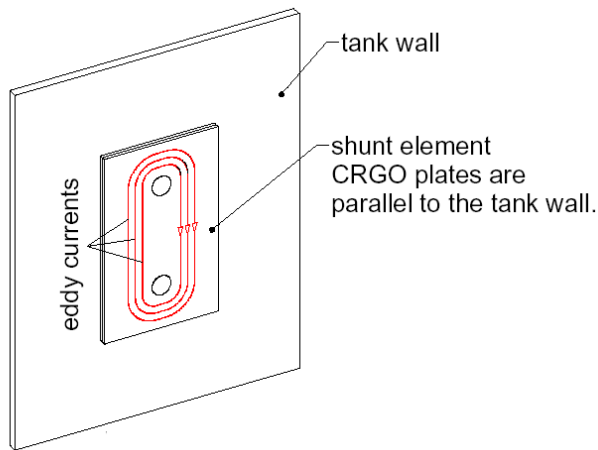
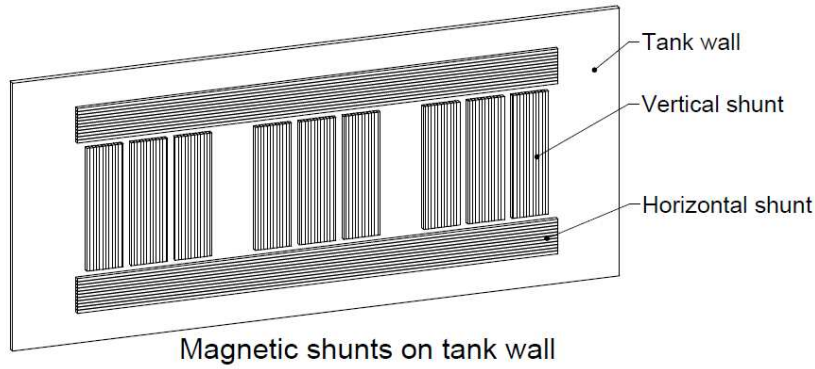

Width –band shunt

In practice there are two types of magnetic shunt elements mostly used. In figure illustrated width- band type. The width- band shunt is placed parallel on the Tank Wall like in the figure. In this type of shunt elements, eddy currents width-band shunt induces stray losses.

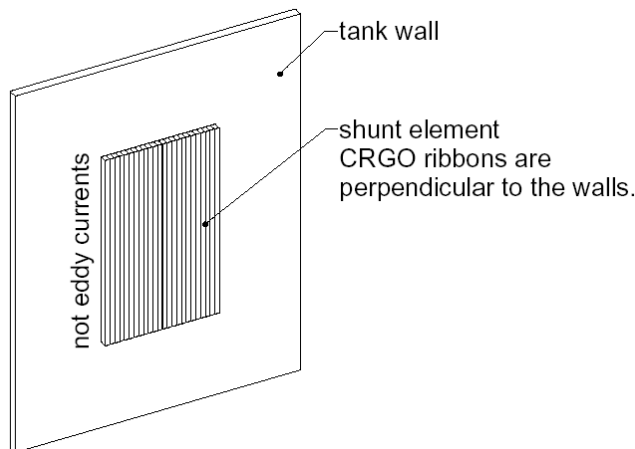

Narrow ribbon edge - wise shunt

The other type of shunt is narrow-ribbon shunt. In this type the ribbons are placed perpendicular to the wall so the flux is occurrence the thickness of ribbon resulting in negligible eddy loss. This type is preferred to use. [2]

In Shunt Reactor Core Manufacturing Challenges and Solutions:

Eddy currents are induced in the core limb due to fringing flux and cause local overheating. To reduce Eddy Current Losses up to 50 % developed Bevel Edge Core Limbs. By using additional Ring Yoke at the bottom and above the Core Limbs can be reduced the additional Losses up to 10 %. This two challenges gives big opportunity to compete with conventional designs. [5, 6, 7]

4

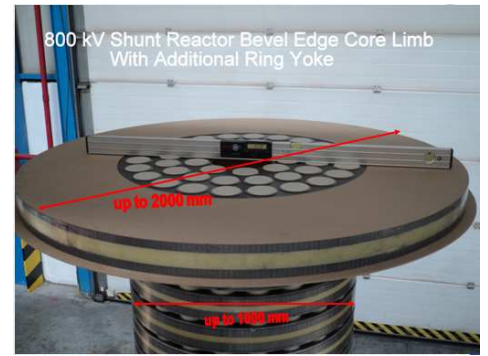
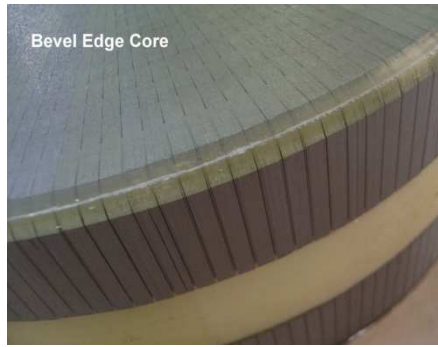

2. CURRENT TRANSFORMERS

For Bushings, for Cables and Gas Insulated Systems (GIS)

The bushing types of CT's are important components of Power Transformers. The Assembled Types used direct under Bushings can save problems. [7]



EXCITATION CURRENT OF CT's IN 3-PHASE SYSTEMS

Excitation current in transformer protection and design of current transformer is a very critical parameter since it effects system protection even if CT is a very small part of the system. In the mean time, it is preferred that the excitation current of the CT's to be placed in each phase of system are close to each other at three phase system. Numerically, it is approximately 10 percent for the CT's produced by ENPAY.

The required excitation current ($I_e / I_{mag} / I_a$) of CT's for class PX, PS and TPS that are mentioned in IEC 60044-1, IEC 60044-6 and IS 2705 standards preferably should be close to each other at 3-phase system. We provide that the differences of measured current value between each other less than 10% if it's defined at an inquiry.

In the mean time, the excitation current is important to define CE (composite error) value for P and C protection classes in IEC 60044-1 & IEEE C 57.13 standards. CE value is a critical parameter for these type protection classes. We also provide that the differences of calculated CE value between each other less than 10% if it's defined at an inquiry.

ENPAY Endüstriyel Pazarlama ve Yatırım A.Ş.

Karadenizliler Mahallesi Fakülte Caddesi, No: 147/A PK. 91, 41140 Başiskele - KOCAELI / TURKEY

Tel: +90 262 349 58 20 Fax: +90 262 349 58 30

3. INSULATION TECHNOLOGY, TRANSFORMERBOARD

It is commonly well-known that life of a transformer depends on the life of insulating paper and Transformerboard. Insulating oil plays an important role in ageing and thus on the life of insulating paper. Cellulose based insulation is the best material for liquid immersed transformers.

Transformerboard is manufactured from unbleached sulphate cellulose (PULP) in HOT PRESS PROCESS, state-of-the-art technology. Pulp extracted from softwood by a chemical process. It is always a high-purity electrical grade pulp, string end specifications are in effect for conductivity, extracted pH, ash and shive content.[11]

5

Precise testing facilities and extensive quality controls are essential in order to guarantee best quality of board material. Some of important online test equipments of the manufacturing are metal detectors (after board machine and after pres) and surface inspection control system, thickness measurement, moisture and density measurement. In Enpay insulation laboratory physical, chemical, cellulose, pulp, paper and electrical (high voltage) tests are performed. The types of raw materials tested:

Pressboard, press paper- IEC 60641/laminated board IEC 60763
Laminated wood IEC 61061/craft paper and crepe paper IEC 60554



The below curves are showing the board quality as a benchmark test from different supplier.

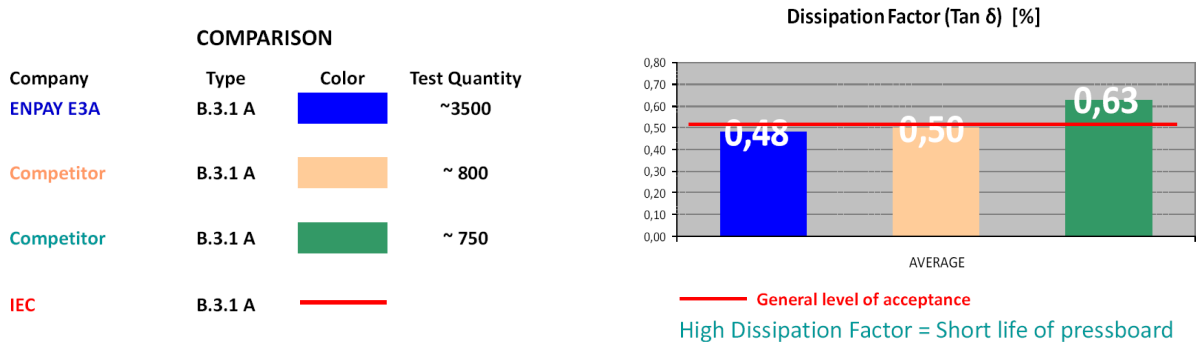

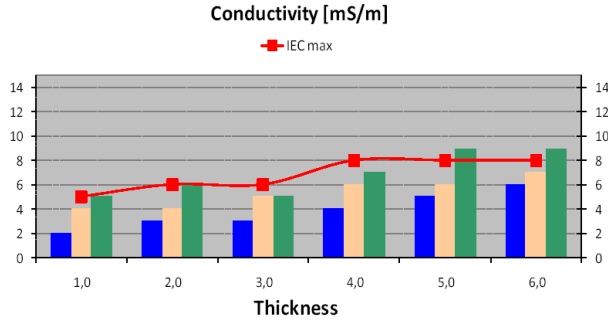

High Conductivity is creepage discharge on the pressboard

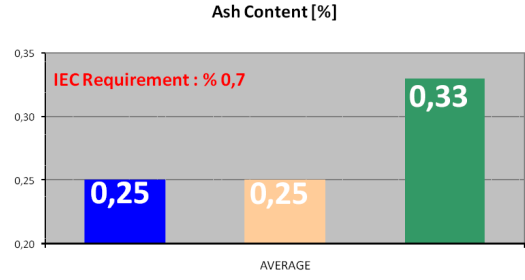

Ash content which shows the pureness of cellulose and the lifetime of pressboard affects the transformer's life.

6

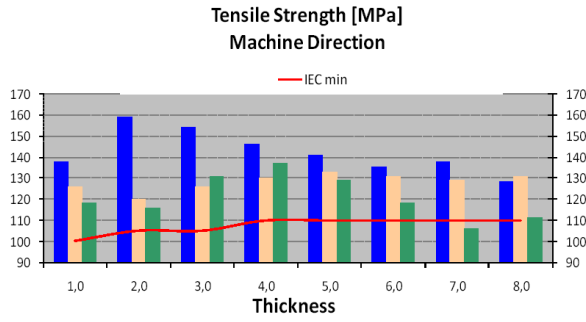

High tensile strength is essential for long transformer life.

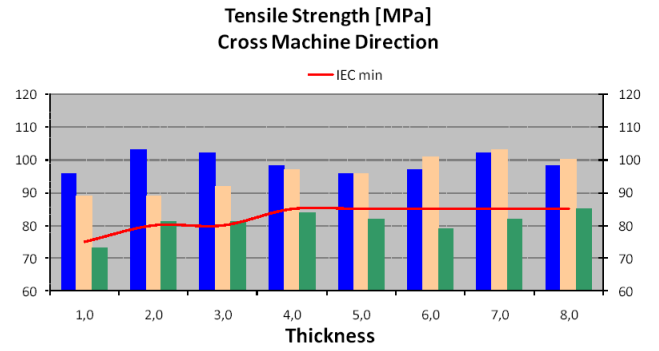

High tensile strength is essential for long transformer life.

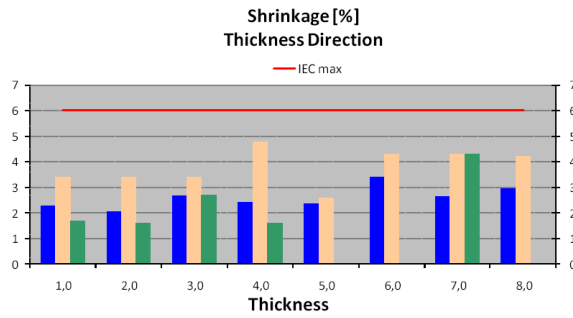

Shrinkage should be minimum for reduce the cost of transformer

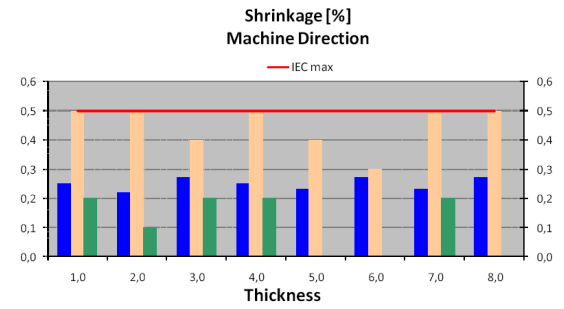

Shrinkage should be minimum for reduce the cost of transformer

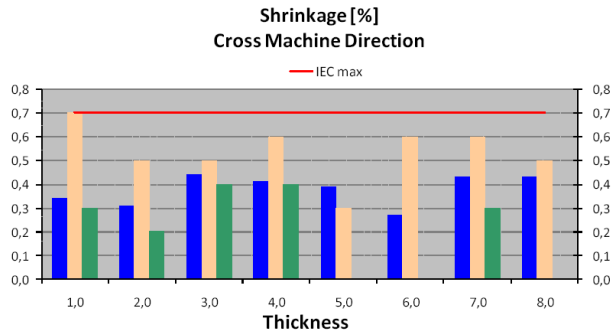

Shrinkage should be minimum for reduce the cost of transformer

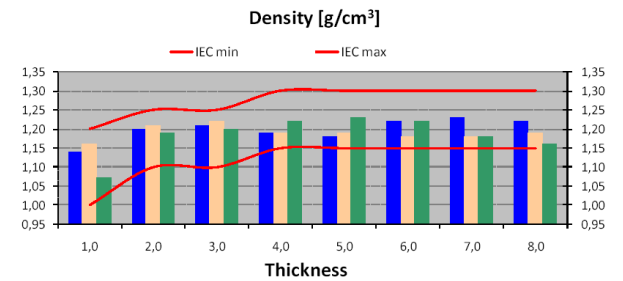

Density should be optimized for mechanical strength and oil absorption

COMPONENTS FOR TRANSFORMER INSULATION

In insulation design, field stress distribution between oil impregnated solid insulation is taken as the fundamental criteria. In AC transformers this stress is distributed in accordance with the permittivity of insulating materials and the geometry.

Economic Design of Lead Exits and Optimized Barrier Systems

7

It is fact that since last few years to have successful economic results of lead Exits and Barrier Systems. [9, 10]

Conventional lead exits with craft (crepe)

Paper wrapped main conductor and Single wide oil gap have anomalous breakdowns and so that big risk. This is not an economical solution.

Complete insulation kits (packages)

Kits allows for less production costs and decreased manufacturing Cycle time of power transformer production. There are a lot of technical and economical advantages to use the kits.



Moulded components

Moulded parts like snouts, angle ring sectors, caps, any kind of wet mold parts from different geometry have a lower density.

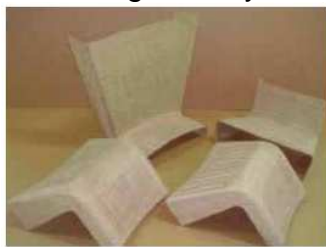

Various insulation components



ENPAY Endüstriyel Pazarlama ve Yatırım A.Ş.

Karadenizliler Mahallesi Fakülte Caddesi, No: 147/A PK. 91, 41140 Başiskele - KOCAELI / TURKEY

Tel: +90 262 349 58 20 Fax: +90 262 349 58 30

CONCLUSION

Life time of Transformers is affected by Design, Manufacturing and Material Quality. The expectation of the operational life span is approximately at least 40 years when used in normal operation. New Manufacturing solutions and designs for Components can help Transformer Optimization. The paper provides in which major areas for Transformers and Reactors are most important study and design and general requests for core design. Furthermore we presented how to collect the Stray Flux in Tank and Yoke.

State-of-the-art manufacturing of Shunt Reactor Cores have big advantages with Bevel Edge Limbs and additional Ring yokes.

Measured Qualities of some important Transformerboard Specifications from different supplier are presented with curves. It is interesting to know the Benefit of the Barrier system in Lead Exits against conventional paper wrapping. It is technically better as well as cost effective. This Information is very important for Grids also.

REFERENCES

- [1] V.K. Lakhiani, T.K. Ganguly, G.R. Mohan, R. Gopala Krishna and G. Sreelatha, Design Experience of a 1200 kV. Transformer, Gridtech 2011, Proceedings. April 19-21, 2011
- [2] S.V.Kulkarni, S.A.Khaparde, Transformer Engineering, Design and Practice, 2004 Marcel Dekker, New York, Basel
- [3] S.Yurekten, Type of Magnetic Materials and Field of Application, Electrotech, 2007
- [4] S.Yurekten, Innovation in Transformer Manufacturing Amorphous Metal Cores for Environmental-Green Transformers, Travek 2011 Moscow
- [5] S. Yurekten, K.Eckholz, Shunt Reactor Cores up to 800 kV.-300 MVAr ARWtr 2010 Spain/IEEE
- [6] S.Yurekten, New Trends in UHV Shunt Reactor Core Technology, Travek 30.03.2011, Moscow, Gridtech2011, April 19-21, proceedings New-Delhi International & Conference
- [7] S.Yurekten, How to reach the Quality Excellence in Transformer Technology with tailor-made components, Travek 8-9 November, 2011 Moscow
- [8] S.Yurekten, E.Ozturk, F.Erenler, Insulation Components for HV Power Transformers, Travek 21-22 June 2011, Moscow, Trafosem-2011 11. International Conference, New-Delhi, 21-22 November 2011

- [9] S.Yurekten, E.Oztürk, Technical Assessment of Lead Exit and Design Process for HV. Power Transformers, Travek, June 2010, Moscow,
- [10] S.Yurekten, E.Ozturk, Technical Assessment of Lead Exit and Design Process for Power Transformers up to 1200 kV. International conference On Development of 1200 kV. National Test Station, September 2010, New-Delhi, National Cigre.
- [11] S. Yurekten, Transformerboard, 3E Electrotech, febr.2010